

## Use and Maintenance Manual

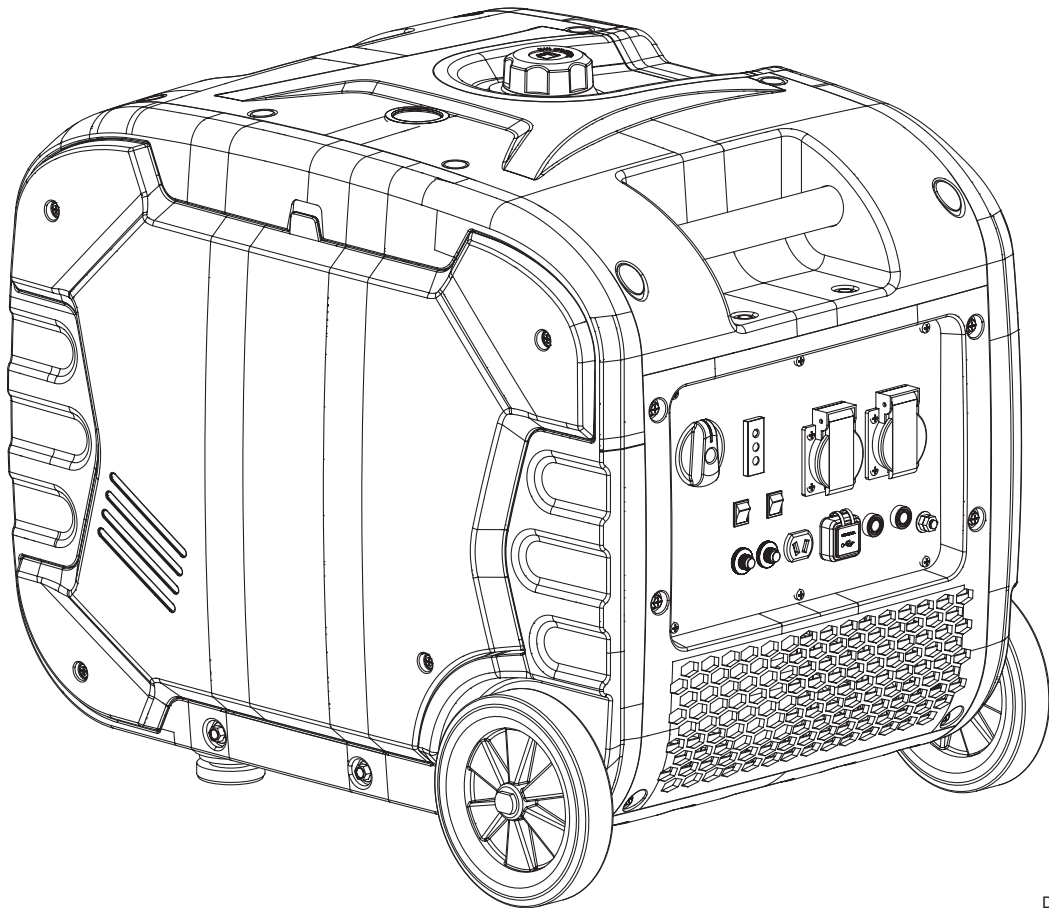

D5262270

# Inverter Generator GE 4500 MI-EAS



Original instructions

<b>1.</b>	<b>Introduction .....</b>	<b>1</b>
1.1	Foreword .....	1
1.2	Supplied documentation .....	1
1.3	Customer service .....	2
1.4	Spare parts .....	2
1.5	Declaration of conformity .....	2
1.6	Unauthorized changes .....	2
1.7	Allowed and non-allowed use .....	2
1.8	Identification data .....	3
1.9	Sound power level .....	4
<b>2.</b>	<b>Safety .....</b>	<b>5</b>
2.1	Safety information .....	5
2.2	Positioning of safety decal and information .....	6
2.2.1	Decal explanation .....	6
2.3	General precautions .....	8
2.3.1	Personal protective equipment .....	8
2.3.1	Check the work area .....	8
2.4	Fire prevention .....	9
2.4.1	Fire due to fuel, oil .....	9
2.4.2	Fires caused by flammable material build-up .....	9
2.4.3	Fire caused by electrical wiring .....	9
2.4.4	Fire caused by piping .....	9
2.5	Lifting and transport precautions .....	9
2.5.1	Lifting and manual transport .....	9
2.6	Precautions for positioning the machine .....	9
2.6.1	Positioning site precautions .....	9
2.6.2	Precautions for electric connections .....	10
2.7	Precautions during operation .....	10
2.8	Precautions against noise .....	10
2.9	Precautions during fuel and engine oil filling .....	11
2.10	Maintenance precautions .....	11
2.11	Precautions for disposal of waste material .....	12
2.12	Disposal of the machine .....	12
<b>3.</b>	<b>Technical data .....</b>	<b>13</b>
3.1	GE 4500 MI-EAS technical data .....	13
3.2	Electrical diagram .....	14
<b>4.</b>	<b>Description .....</b>	<b>15</b>
4.1	Main components .....	15
4.2	Control panel components .....	16
4.2.1	Explanation of control panel components .....	17
<b>5.</b>	<b>Delivery, unpacking and installation .....</b>	<b>20</b>
5.1	Delivery .....	20
5.2	Unpacking .....	20

<b>6.</b>	<b>Operation .....</b>	<b>22</b>
6.1	Connection to a home system.....	22
6.2	Total load.....	23
6.3	Simultaneous use of alternating current and direct current supply .....	23
6.4	Grounding.....	24
6.5	Checks before start-up .....	25
6.6	Starting and stopping the engine.....	25
	6.6.1 Starting the engine.....	25
6.7	Alternating current operation (AC).....	28
6.8	Direct current operation (DC) .....	29
	6.8.1 Charging a battery .....	29
6.9	Connecting in parallel mode.....	30
6.10	Troubleshooting.....	31
<b>7.</b>	<b>Maintenance.....</b>	<b>32</b>
7.1	Ordinary Maintenance Schedule .....	32
7.2	Fuel .....	33
7.3	Engine oil.....	33
7.4	Engine air filter .....	35
	7.4.1 Cleaning.....	35
	7.4.2 Replacement.....	35
7.5	Cleaning the spark guard .....	36
7.6	Checking and replacing the spark plug .....	37
7.7	Cleaning the fuel tank filter .....	37
7.8	Storage .....	38
7.9	Disposal .....	38

## 1. Introduction

### 1.1 Foreword

This manual supplies the Operator and qualified and authorised Technicians with technical information on the GE 4500 MI-EAS Inverter generator (hereinafter also referred to as the “machine”) produced by MOSA Div. of BCS S.p.A. (hereinafter also referred to as the “manufacturer”).

In this manual, the Operator in charge and the qualified Technicians will find the indications for:

- Getting familiar with the safety measures and basic standards to be adopted, to prevent hazards and damage to people, to the machine and to the environment.
- Getting to know the main components of the machine and its operation.
- Performing the programmed routine maintenance.
- Getting to know any extraordinary maintenance operation.

This manual is an integral part of the machine and must follow it in any changes of ownership, until the final dismantling.

The manual and all the publications attached to it must be kept with care, in an easily accessible place, known to the operator and to the qualified technicians authorized for maintenance. Read the descriptions carefully before starting to work or carrying out the required adjustments or maintenance.

If the manual is lost, damaged or becomes illegible, request a copy to MOSA, indicating the model of the machine, the serial number and the year of construction.

If the machine is transferred, the transferor must deliver this manual to the new owner.

The machine is subject to updates to improve its performance; this manual summarises the information regarding the current state of technology at the moment of the supply.

MOSA reserves the right to make improvements and modifications to parts and accessories, without promptly updating this manual, except in exceptional cases of fundamental integrations concerning safe operation.



#### **CAUTION**

- **Improper use or maintenance can cause serious damage to people and shorten the “useful life” of the machine.**
  - **The Operator and the qualified Technicians must be familiar with all the indications given in this manual before using the machine or carrying out maintenance operations on it.**
  - **The procedures contained in this manual are intended to be applicable to machine only for permitted uses, and with all safety devices in function.**
- If the machine is used for purposes other than those indicated or in safety conditions other than those indicated, the Customer becomes directly responsible for any person possibly involved in accidents or injuries and for abnormal wear and tear of the machine.**

### 1.2 Supplied documentation

The documents supplied with the machine include this Use and Maintenance Manual.

## 1. Introduction

### 1.3 Customer service

The Technical Assistance and Spare Parts Service are available to the Customers.

MOSA recommends that you contact the nearest authorised service centre for specialised intervention for all control and overhaul operations.

In order to obtain quick and effective responses, indicate the Model and Serial Number shown on the identification plate (see “1.8 Identification data”).

### 1.4 Spare parts

Only original spare parts that guarantee functionality and durability must be used.

The use of non-original spare parts will void all warranty and Technical Support obligations.

### 1.5 Declaration of conformity

The manufacturer:

MOSA Div. of BCS S.p.A.

Viale Europa, 59 20047 Cusago (Milano) Italy

Declares that the machine:

GE 4500 MI-EAS

Complies with the requirements of the following EC/EU Directives:

- Machine Directive 2006/42/EC
- Low Voltage Directive 2014/35/EU
- Electromagnetic Compatibility Directive 2014/30/EU
- Noise Emission Directive for machines intended to operate outdoors 2000/14/EC as amended by 2005/88/EC

and with the requirements of the following UK regulations:

- The Supply of Machinery (Safety) Regulations 2008/1597
- The Electrical Equipment (Safety) - Regulations 2016/1101
- Electromagnetic Compatibility - Regulations 2016/1091
- The Noise Emission in the Environment by Equipment for use Outdoors - Regulations 2001/1701

### 1.6 Unauthorized changes

No changes can be made to the machine without MOSA'S authorization.

Unauthorized changes void any form of warranty on the machine and any civil and/or criminal liability in case of accidents or injuries

### 1.7 Allowed and non-allowed use

This machine is used to generate electrical current in accordance with the specifications of the declared electrical system.

The Inverter technology provides a clean and stable power, ideal for a wide range of applications, in particular for sensitive electronic devices.

Integrated USB ports allow mobile devices to be charged and a 12Vdc DC output allows small lead-acid batteries to be charged.

## 1.8 Identification data

The data identifying the machine are specified on the ID plate applied in the area indicated in the figure. They are necessary for spare parts requests and communications with the Customer Service Department.

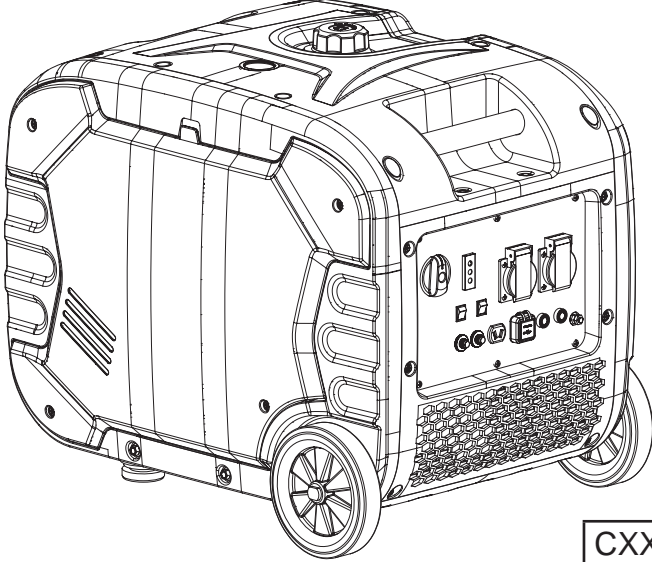

CXXXXX (Serial N./Matricola) B

A	<b>MOSA</b>	Low-power generating set	CE			
B	Model: GE4500 MI-EAS		EN ISO 8528-13			
C	Rated Power	3.8kW	Rated Voltage	230V	Quality Class	B
C	Maximum Power	4.2kW	Rated Current	16.5A	Performance Class	G1
C	Rated Frequency	50Hz	Mass Weight	42kg	Power Factor	1.0
A	IP Grade	IP23M	Year of manufacture		2023	B
A	BCS S.p.A. Viale Europa 59 - 20047 Cusago (MI) ITALY - www.mosa.it					

A. Dati del costruttore

B. Dati della macchina

- *Model*: modello
- Norma Tecnica di riferimento
- *Year of manufacture*: Anno di costruzione
- *Serial No.*: Matricola macchina

C. Dati tecnici della macchina

- *Rated Power*: Potenza nominale - kW
- *Maximum Power*: Potenza massima - kW
- *Rated Frequency*: Frequenza nominale Hz
- *IP Grade*: Grado di protezione IP
- *Rated Voltage*: Tensione nominale - V
- *Rated Current*: Corrente nominale - A
- *Mass Weight*: Peso a secco (kg)
- *Quality Class*: Classe di qualità - Uscita
- *Performance Class*: Classe di prestazione - Uscita
- *Power Factor*: Cosφ nominale (fattore di potenza)

## 1. Introduction

### 1.9 Sound power level

The sound power level of the Inverter generator is given on the decal applied in the area indicated in the figure.

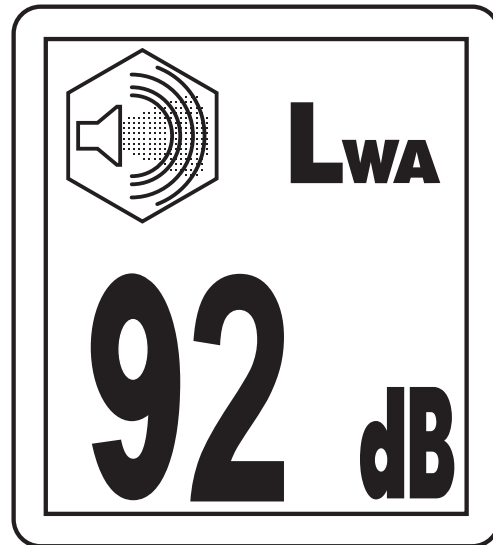
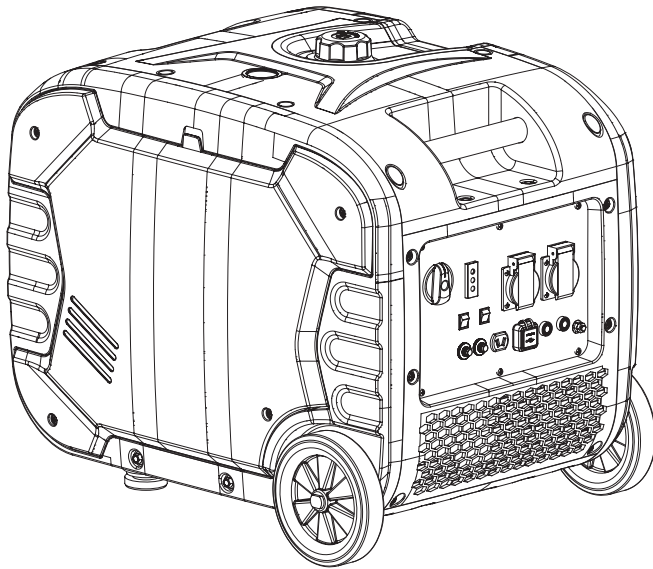

The value indicates the guaranteed sound power level in compliance with Directive 2000/14/EC.

- Sound power level (LWA) - Unit of measurement dB(A): represents the amount of acoustic energy emitted in the unit of time regardless of the distance of the measuring point.

## 2. Safety

### 2.1 Safety information

Always respect the warnings contained in this manual and present on the decal applied to the machine. This allows the machine to be used safely, avoiding damage to property and injury or death to people. The following words and symbols were used to identify important safety messages.

Symbol  identifies important safety messages on the machine, in the manual and elsewhere. When you see this symbol, follow the instructions in the safety messages.



#### **DANGER**

- This word indicates a situation of imminent risk that, if not avoided, could cause serious injury or even death to people and serious damage to property.



#### **WARNING**

- This word indicates a potential risk situation which, if not avoided, could result in serious injury or even death to people and serious damage to property.



#### **CAUTION**

- This word indicates a potential risk situation that, if not avoided, could cause minor or moderate injuries.  
It can also be used to prevent dangerous operations that can cause damage to the machine.

The following terms are used to transmit the information to be followed to the user, to avoid damage to the machine.



#### **Important**

- If the precautions described are not observed, the machine could be damaged and its useful life reduced

#### **Note:**

- This word is used to indicate further useful information.

## 2. Safety

### 2.2 Positioning of safety decal and information

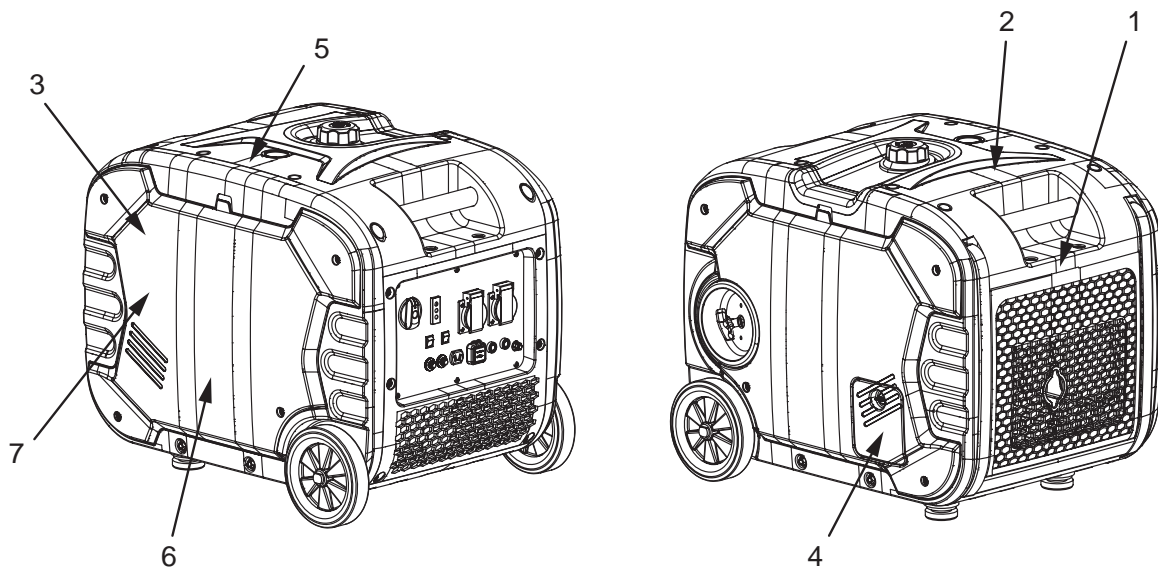

#### 2.2.1 Decal explanation

	<ul style="list-style-type: none"> <li>Pos. 1 - Attention! High temperature. Do not touch! To avoid burns due to contact with hot parts, stop the engine and wait until it has sufficiently cooled down.</li> </ul>
	<ul style="list-style-type: none"> <li>Pos. 2 - Refer to the manual While using this machine, beware of the danger of fires, explosions, inhalation of toxic gases and burns due to high temperature. Refer to the instruction manual and follow the safety instructions described.</li> </ul>
	<ul style="list-style-type: none"> <li>Pos. 3 - Engine spark plugs Consult the manual before removing the engine spark plugs.</li> </ul>
	<ul style="list-style-type: none"> <li>Pos. 4 - Access cover for engine oil control, top-up and replacement.</li> </ul>

<p><b>STARTING</b></p> <p>OPEN THE VALVE OF FUEL TANK CAP</p> <p>ESC THROTTLE TURN ESC SWITCH TO "ON"</p> <p>TURN SWITCH TO "CHOME"</p> <p>PULL ENGINE START</p> <p>TURN SWITCH TO "ON" SLOWLY</p> <p>INDICATOR LIGHT TURNS GREEN</p>	<ul style="list-style-type: none"> <li>Pos. 5 - Starting procedure.</li> </ul>
	<ul style="list-style-type: none"> <li>Pos. 6 - For disposal, comply with Directive 2012/19/EU on waste of electric and electronic equipment (WEEE).</li> </ul>
<p>Remove the access cover from the back panel. Connect the wires connector.</p>	<ul style="list-style-type: none"> <li>Pos. 7 - Remove the panel to connect the starter battery for electric starting.</li> </ul>

## 2. Safety

### 2.3 General precautions

Any errors during use, checks or maintenance could cause the risk of injury, even serious

- Before performing the operations, read this manual and the decals applied to the machine and follow the warnings.  
If you don't understand any part of the manual, ask your Safety Officer for explanations.
- The machine can only be used and repaired by trained and authorized personnel.
- Do not work if you feel unwell, have drunk alcohol or take medicines that impair your ability to work safely or repair the machine.
- Before starting the operations, check the machine. If anomalies are detected, do not operate on the machine before having completed the necessary repairs.
- Comply with the provisions and laws in force in the country in which you work.

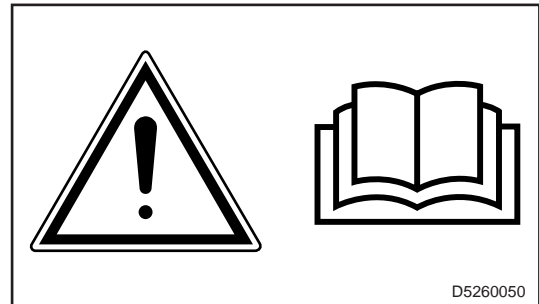

#### 2.3.1 Personal protective equipment

- During maintenance (engine oil replacement, spark plug cleaning, etc.), wear personal protective equipment, such as safety footwear and gloves.
- Before using personal protective equipment, check that it is in perfect condition.



#### 2.3.1 Check the work area

- Check that the area is clear of materials that may be hazardous during the operation of the Inverter generator (such as flammable materials or liquids).
- Make sure that no one (especially children) approaches the area where the power generator is positioned and running.

## 2.4 Fire prevention

### 2.4.1 Fire due to fuel, oil

- Avoid approaching any flame to flammable substances such as fuel and oil.
- Do not smoke or use open flames near flammable substances.
- Stop the machine before refuelling.
- Make sure not to spill flammable substances on over heated surfaces or on parts of the electrical system.
- After refuelling, remove any spills and tighten all filling caps tightly.
- For safety in the workplace, store the cloths soaked in flammable materials in a container.
- Store oil and fuel in pre-established and well ventilated locations and prohibit the entry of unauthorised personnel.
- When cleaning the machine, do not use flammable substances such as diesel or gasoline.



### 2.4.2 Fires caused by flammable material build-up

- Remove dry leaves, chips, pieces of paper, carbon dust, or other flammable materials accumulated from the machine.

### 2.4.3 Fire caused by electrical wiring

- Always keep the electrical wiring clean and tightened.
- Periodically check that there are no loose or damaged parts. Tighten loose wiring connectors or terminals.
- Repair or replace any damaged cables.

### 2.4.4 Fire caused by piping

- Periodically check that the hose clamps are firmly fixed.
- If loosened, they may vibrate during machine operation and cause leakage of liquids, provoking fires and serious injuries, including fatalities.

## 2.5 Lifting and transport precautions

### 2.5.1 Lifting and manual transport

- Handle the machine with the special handle.
- Handle the machine with the engine off, the electrical cables disconnected and the fuel tank empty.

## 2.6 Precautions for positioning the machine

### 2.6.1 Positioning site precautions

- The machine may not be used indoors, such as in homes and garages, even if the doors and windows are open.

This machine has been designed for outdoor use and can therefore be positioned outdoors.

In case of meteorological precipitation (rain, snow, etc.), place the machine in an adequately sheltered place. If this is not possible, do not use the machine.

- Do not place machines or equipment near heat sources, in areas at risk with explosion hazard or fire hazard.

Place the machine at a safe distance from fuel tanks, from flammable material (rags, paper, etc.), from chemicals.

Follow the instructions of the competent authorities.

## 2. Safety

- To limit potentially dangerous situations, isolate the area around the machine, thus preventing any unauthorized personnel from getting close to it.  
Although the machines produced comply with the regulations on electromagnetic compatibility, do not place the machine near equipment influenced by the presence of magnetic fields.
- Make sure that the area immediately surrounding the machine is clean and free of debris.
- Always place the machine on a flat, solid surface that is not subject to failure in order to avoid tipping,-slipping or falling during operation.
- The machine must always be positioned so that exhaust gases disperse into the air without being inhaled by people or animals.
- The exhaust gases of an engine contain carbon monoxide: this substance is harmful to health and, in high concentration, can cause poisoning and death.
- If the machine is used indoors, make sure that the area is well ventilated.

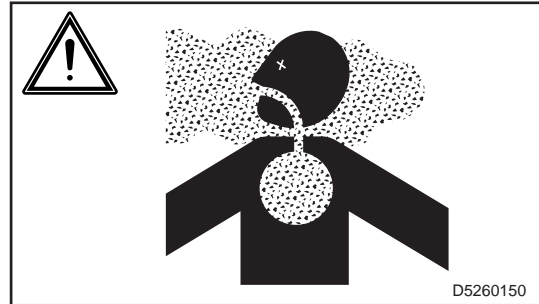

### 2.6.2 Precautions for electric connections

- Use appropriate electrical plugs at the machine output sockets and make sure that the electrical cables are in good condition.
- Do not use the machine with wet or damp hands and/or clothing.

### 2.7 Precautions during operation

- Immediately stop the machine in case of malfunctions.  
Do not restart the machine without first identifying and solving the problem.
- Do not wrap or cover the machine with cloths while it is running. Before covering the machine, make sure that the engine parts are cold  
If the engine parts are still warm, there is a risk of damage to the machine and fire.
- Do not place objects or obstacles near the air suction and expulsion windows; a possible overheating of the generator could cause a fire.

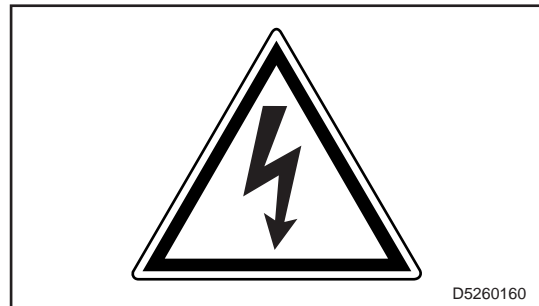

### 2.8 Precautions against noise

- Excessive noise can cause temporary or permanent hearing problems.  
The actual risk arising from the use of the machine depends on its use conditions.
- There is a decal on the machine that declares the sound power level dB(A) emitted by it. The value provides an indication of the noise level emitted by the machine when used, in order to assess the noise in the environment where the generator is placed.
- The adoption of specific measures (such as headphones or earplugs) must be assessed by the operator.

### 2.9 Precautions during fuel and engine oil filling

- Fuel and engine oil are flammable. Refill with the engine off.
- Refuel only outdoors or in well-ventilated environments.
- Do not smoke or use naked flames during refuelling.
- Do not fuel with the engine running or hot.
- Clean and dry any leaks of engine oil and fuel before restarting the machine.
- After refuelling, fully tighten the tank caps.
- Do not fill the fuel tank completely to allow expansion of the fuel inside it.
- Do not exceed the MAXIMUM engine oil level.



### 2.10 Maintenance precautions

- Stop the machine and disconnect all electrical devices.
- To avoid injury, do not perform maintenance with the engine running.
  - Rotating parts, such as the fan, are dangerous and can get entangled on body parts or a worn object. When performing maintenance, be careful to approach rotating parts.
  - Make sure not to drop or insert tools or other objects in the fan or other rotating parts. They can touch the rotating parts and be projected.
- Do not touch the engine, pipes and muffler during operation or immediately after shut-off. Allow the engine to cool before performing any operation.
- When discharging the engine oil, the engine must be hot. Engine oil may come into contact with the skin and cause burns.
- Do not remove the guards and safety devices. If it is necessary to remove them, after completing the maintenance, install the removed guards and restore the safety devices.
- Use work tools in good condition and suitable for the work to be performed. If you use a damaged or deformed tool or if you use a tool for a purpose other than its intended purpose, there is a danger of causing serious personal injury or death.
- Be careful not to damage the electric starter battery, as it contains lithium. If lithium leaks out and comes in contact with oxygen in the air, it can catch fire causing an explosion.

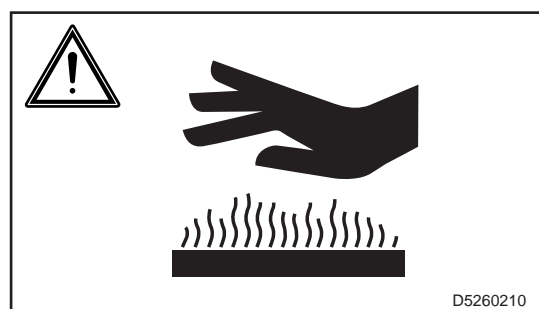
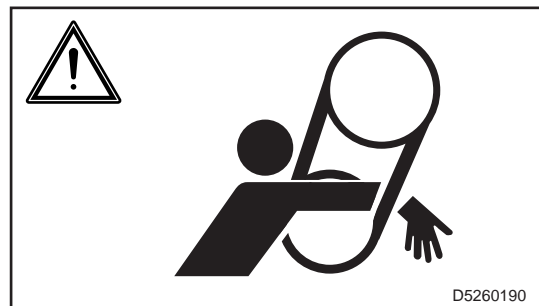

## 2. Safety

### 2.11 Precautions for disposal of waste material

- Be sure to store the waste liquid in containers or tanks.
- Do not discharge the oil directly into the soil or sewage system, rivers, seas or lakes.
- When disposing of harmful waste such as oil, fuel, coolant, solvents, filters and batteries, follow current laws and regulations.
- Entrust the authorized companies with the disposal of rubber material, plastic and components that contain them (hoses, cables, wiring, etc.) in accordance with the applicable laws and regulations.

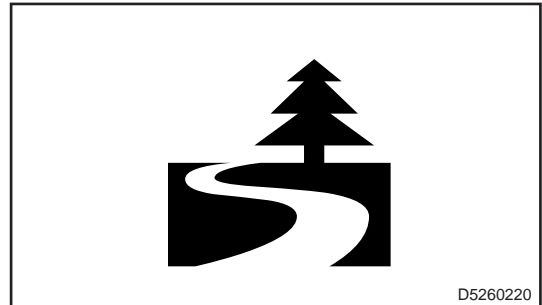

### 2.12 Disposal of the machine

This machine is classified as Electrical Equipment.

For disposal, comply with Directive 2012/19/EU on waste of electric and electronic equipment (WEEE).

The symbol affixed to the product or to the documentation states that, at the end of its useful life, the machine must be disposed of separately.

Adequate separate collection helps avoid possible negative effects on the environment and health and promotes the reuse and/or recycling of the materials that make up the equipment.



### 3. Technical data

#### 3.1 GE 4500 MI-EAS technical data

Model n.		4kW Generator
Generator	Type	Silent Inverter
	Rated frequency (Hz)	50
	Rated voltage (V)	230
	Rated output power (kW)	1.8
	Maximum output power (kW)	1
	Power factor	ISO8528 G2
	Charging Voltage (DC) (V)	12
	Charging Current (DC) (A)	8.3
	Overload Protect (DC)	Protettore non fusibile
Engine	Engine	GK 225I
	Engine typew	Single cylinder, 4-Stroke, forced air cooling, OHV
	Displacement (cc)	223
	Fuel type	Unleaded Gasoline
	Fuel tank capacity (L)	10
	Fuel consumption (g/(kW·h))	≤395
	Continue Running Time (at rated power) (h)	5
	Oil Capacity (L)	0.55
	Spark Model No.	F6RTC/F7RTC
	Starting mode	Recoil starter
Generator set	Length×Width×Height (mm)	605×432×493
	Net weight (kg)	42

### 3. Technical data

### 3.2 Electrical diagram

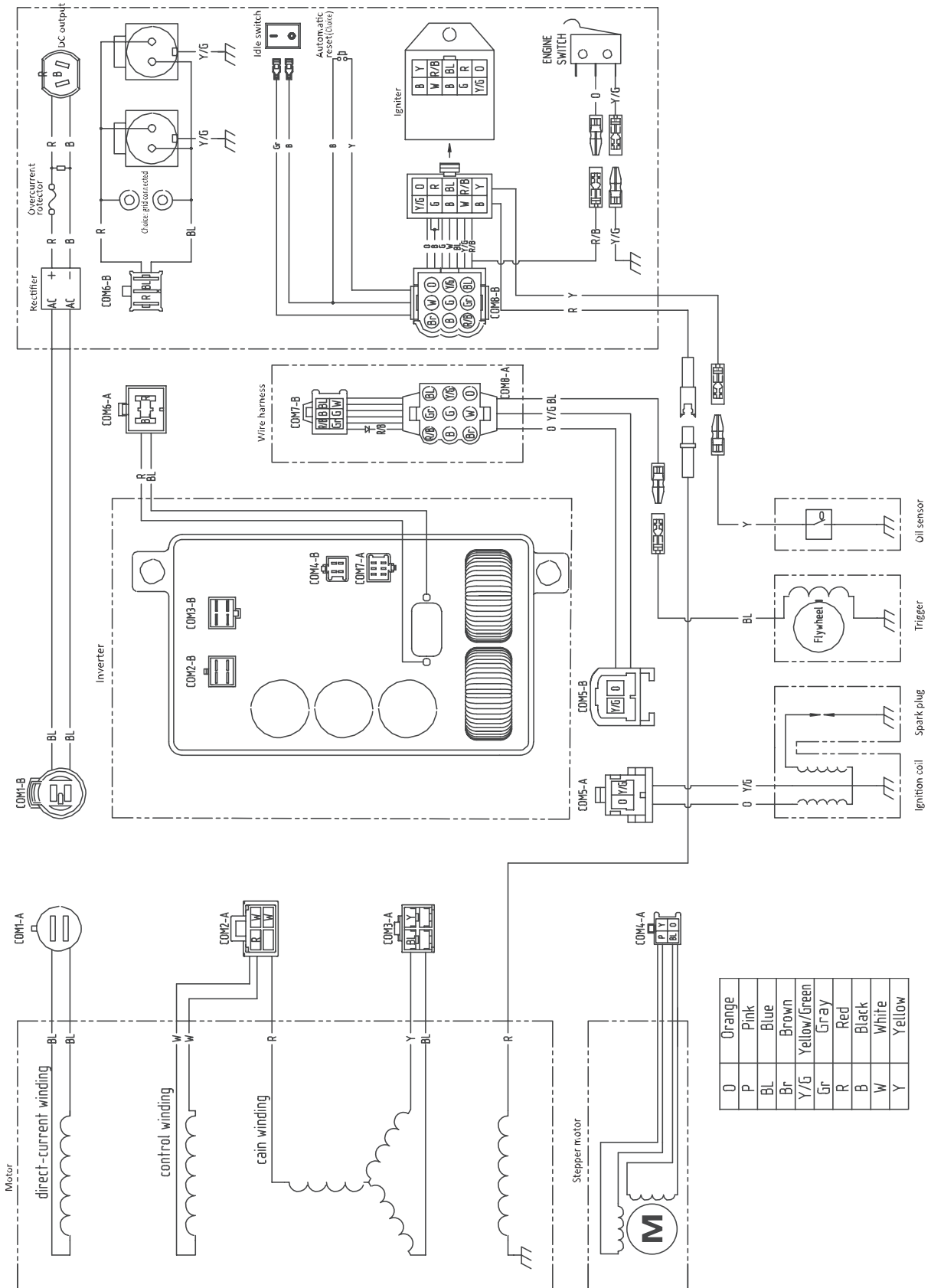

## 4. Description

The Inverter generator is a machine that transforms the mechanical energy generated by a engine into a source of electrical energy with alternating current for powering lighting sources, small appliances and tools, and with direct current for charging batteries.

### 4.1 Main components

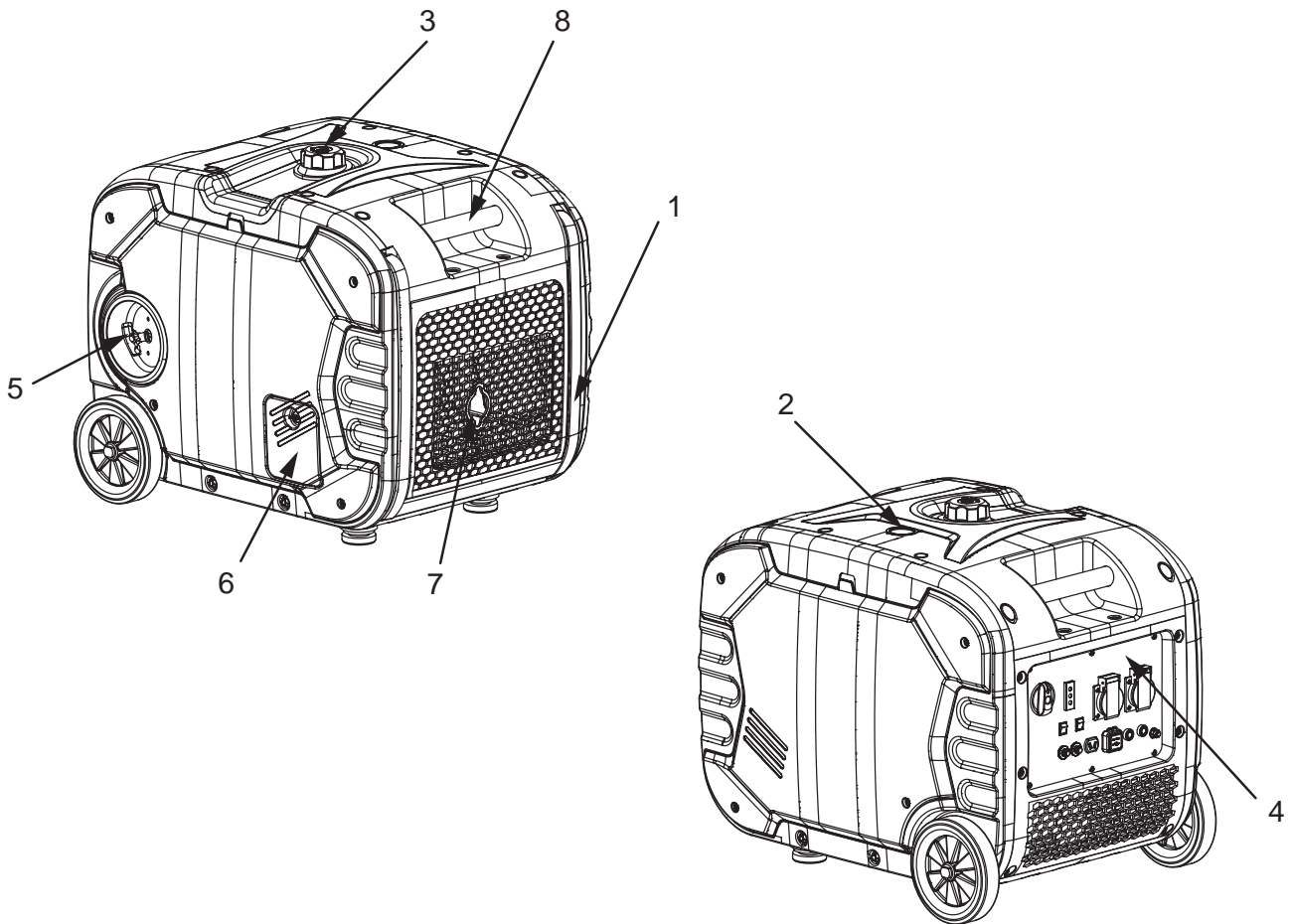

1. Tie rod
2. Oil leveler
3. Fuel tank cap
4. Control panel
5. Ignition knob
6. Oil leveler
7. Fuel tank cap
8. Control panel

## 4. Description

### 4.2 Control panel components

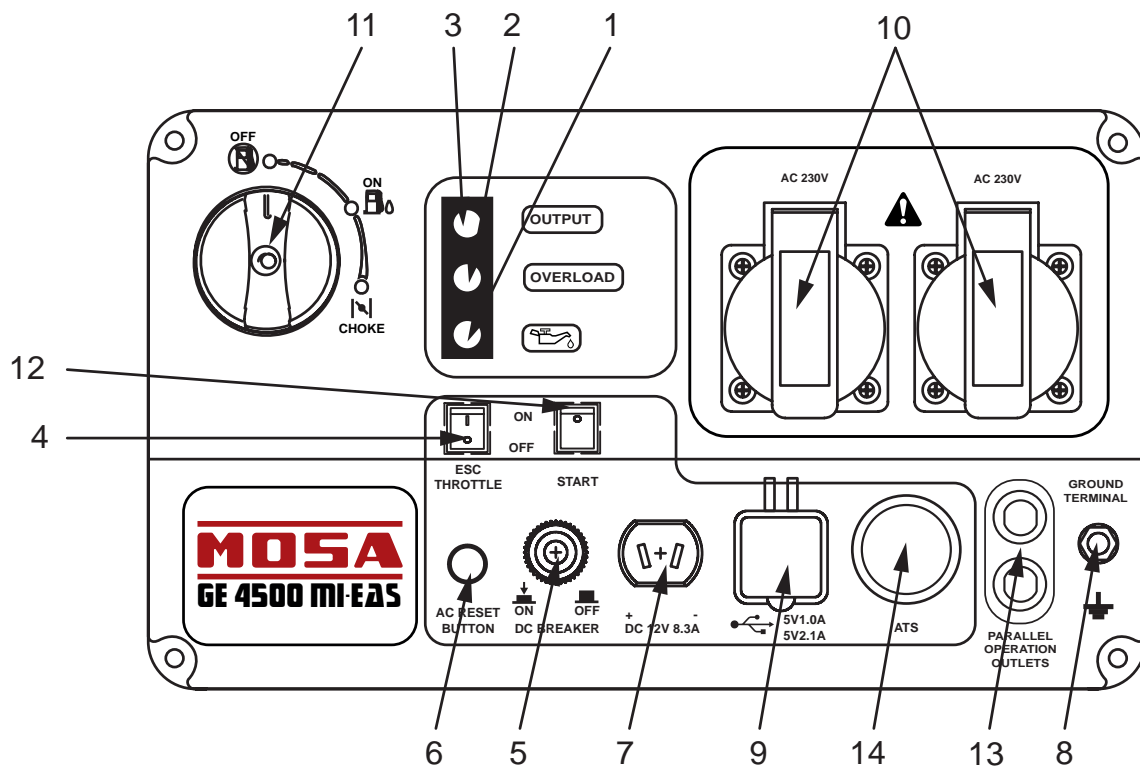

1. Oil warning light
2. Overload indicator light
3. AC pilot light
4. Engine speed control switch (ESC)
5. Direct current protection (DC)
6. AC reset button (Overload)
7. DC socket
8. Ground terminal
9. USB socket
10. Alternating current socket (AC)
11. Multifunction switch (OFF - ON / fuel tap - choke)
12. Electric start button (START)
13. Parallel output
14. Automatic switching(ATS)

## 4.2.1 Explanation of control panel components

### 1 - Oil warning light (red)

When the oil level falls below the lower level, the oil warning light comes on and then the engine stops automatically.

Unless you refill with oil, the engine will not start again.

Tip: If the engine stalls or does not start, turn the engine switch to "ON" and then pull the recoil starter. If the oil warning light flickers for a few seconds, the engine oil is insufficient. Add oil and restart.



### 2 - Overload indicator light (Red)

The overload indicator light comes on when an overload of a connected electrical device is detected, the inverter control unit overheats, or the AC output voltage rises. Then, the AC protector will trip, stopping power generation in order to protect the generator and any connected electric devices. The AC pilot light (Green) will go off and the overload indicator light (Red) will stay on, but the engine will not stop running.

When the overload indicator light comes on and power generation stops, proceed as follows:

1. Turn off any connected electric devices and stop the engine.
2. Reduce the total wattage of connected electric devices within the rated output
3. Check for blockages in the cooling air inlet and around the control unit. If any blockages are found, remove.
4. After checking, restart the engine.

Tip: The overload indicator light may come on for a few seconds at first when using electric devices that require a large starting current, such as a compressor or a submersible pump. However, this is not a malfunction.



### 3 - AC pilot light (Green)

The AC pilot light comes on when the engine starts and produces power.

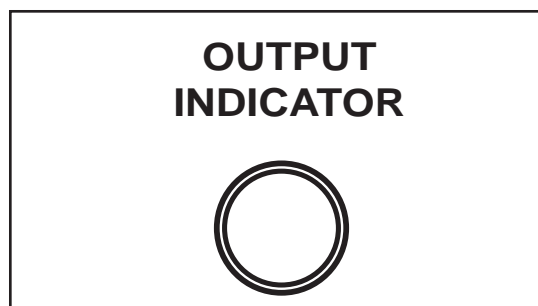

## 4. Description

### 4 - Engine speed adjustment switch (ESC)

- **Pos. ON.**  
When this switch is in the ON position, the engine speed is adjusted according to the connected load, improving consumption and noise.
- **Pos. OFF.**  
When the switch is in the OFF position, the engine speed is set at 3600 rpm.  
It is recommended to leave the switch in this position when connecting devices that require a high load at start-up.

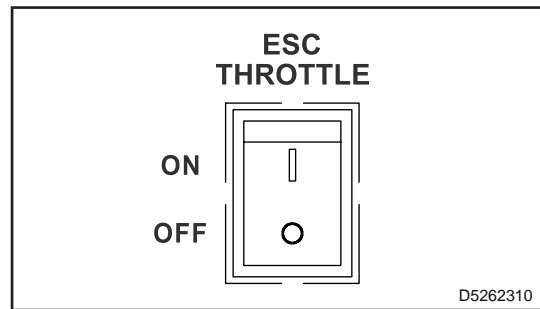

### 5 - Direct current protection (DC)

When the protection is in the ON position, direct current (DC) is supplied.

When the current supplied exceeds the nominal value, the protection is automatically set off by interrupting the direct current (DC) supply.

Disconnect the connected load, allow the protection to cool down and reduce the load to below its rated value.

If the protection intervenes again with a current below the nominal value, contact a Service Centre.

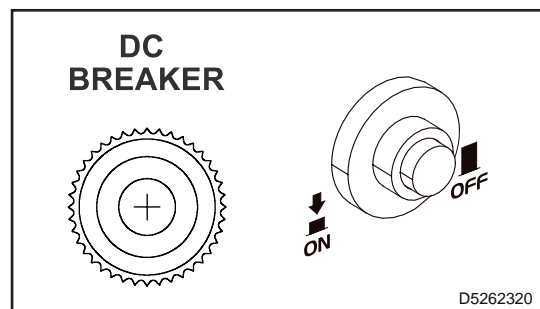

### 6 - AC reset button (overload)

Press the reset button to reset the overload alarm.



### 7 - DC socket

Connect the supplied cable to draw direct DC.

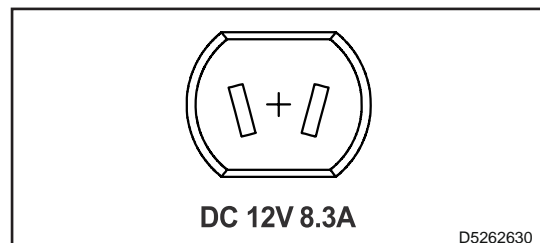

### 8 - Ground terminal

Inverter generator connection terminal to a grounding system.

Use the terminal only if necessary. For details, see "6.4 Grounding".

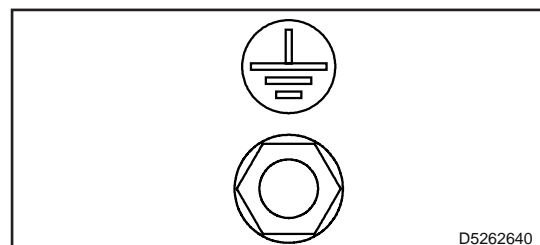

### 9 - Prese USB

Prese USB per la ricarica di dispositivi mobili

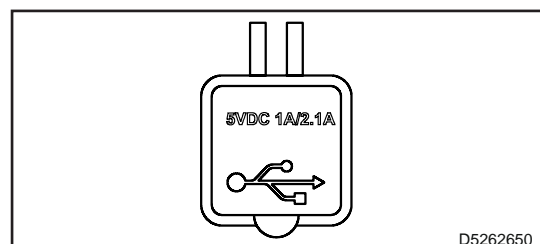

### 10 - Alternating current sockets (AC)

AC electric device connection sockets

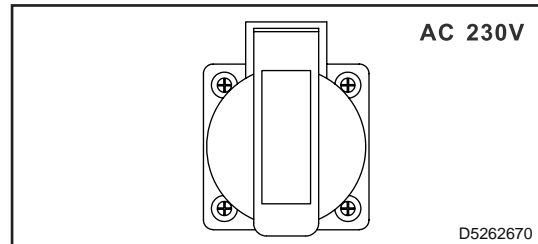

### 11 - Multi-function switch

- **Pos. OFF.**  
In this position, the fuel is closed and the electric ignition circuit prevents starting.
- **Pos. ON.**  
In this position, the fuel is open and the electric ignition circuit is active.
- **Pos. CHOKE.**  
Turn the switch to this position to start.  
In this position, the fuel is open, the electric ignition circuit is active and the carburettor throttle valve is closed. With a hot or ambient-temperature engine, do not turn the switch to the CHOKE position for starting, but leave it in the ON position.

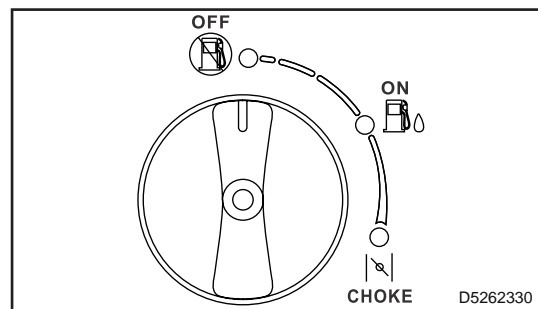

### 12 - Electric start button (START)

Push this button to start the engine electrically.

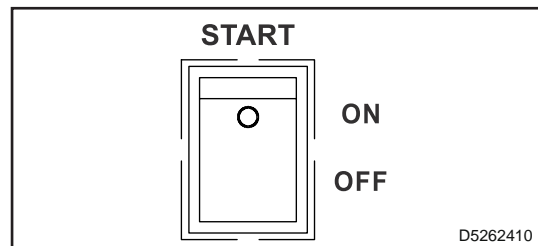

### 13 - Parallel output

Output for parallel connection of two current generators.

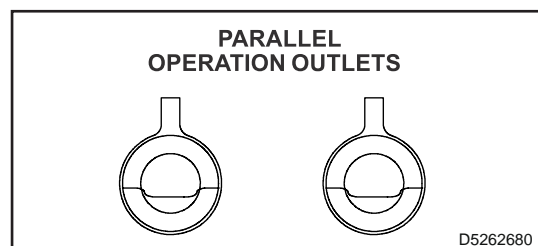

### 14 - Automatic switching(ATS)

Connector for automatic network switching panel EAS-CM40.

The panel is equipped with a charging function for the generator battery.

For further information, see the EAS-CM40 panel manual.

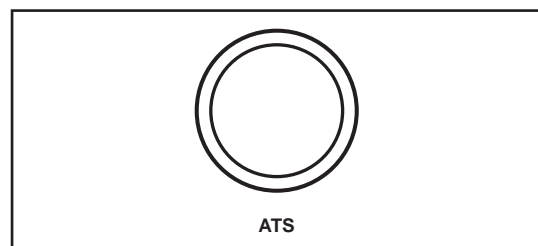

## 5. Delivery, unpacking and installation

### 5. Delivery, unpacking and installation

#### 5.1 Delivery

- The machine is normally transported and delivered packed in a suitable cardboard box.
- All shipped equipment is checked before being delivered to the Client.
- Check the material delivered against the detailed shipment list.

#### Important

- Upon receipt, check the equipment for damage (breakage or significant dents) caused by transport. If this occurs, immediately inform the transport company and write down the "Conditional Acceptance" clause in the delivery note.
- In the event that, at the time of delivery, significant damage is found, caused during transport, together with any missing parts that may be found, promptly notify MOSA Div. of BCS S.p.A.

#### 5.2 Unpacking

- Unloading of the packaging must be carried out with the utmost care, using lifting equipment of a suitable capacity (e.g. forklift truck), if necessary.
- Place the packaging on a stable and horizontal surface.
- Load handling operations must be carried out by qualified personnel, in compliance with the current regulations on safety in the workplace of the country of use.



**Do not dump the packaging into the environment; comply with the regulations in force in the country of use.**

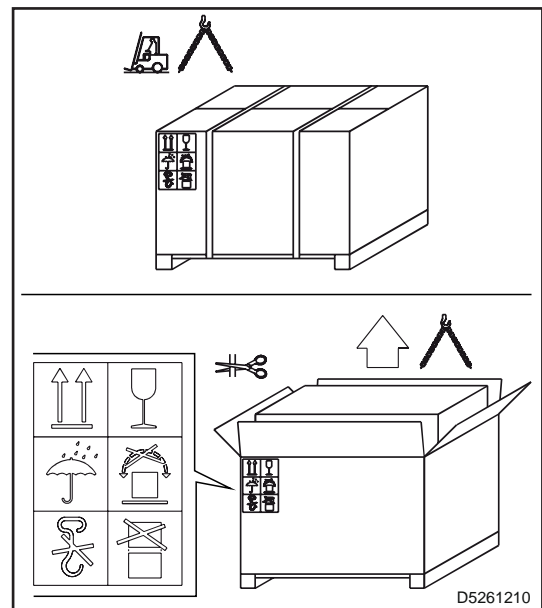

1. Remove the machine (1) and the documents (2) from the packaging.

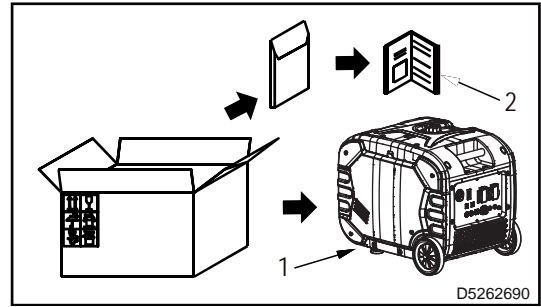

2. Check the machine identification plate, the integrity of the decal and data, and read the use and maintenance manual before proceeding with use.

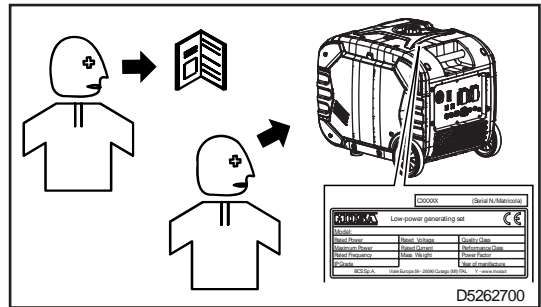

## 6. Operation

### 6. Operation



#### WARNING

- Before positioning and starting the machine, read section “2. Safety” carefully.
- Do not overload the generator because it may get damaged.
- When powering precision equipment, electronic controllers, computers, microcomputer-based equipment or chargers, keep the generator at a sufficient distance to avoid electromagnetic interference caused by the engine.
- If the generator is to supply medical equipment, consult the manufacturer or the competent health authority.
- Some electric appliances or electric engines for general use have high starting currents and cannot be used even if they fall within the power supply fields indicated in the following table. Consult the equipment manufacturer.

#### 6.1 Connection to a home system



#### IMPORTANT

- Connection to the domestic system must be carried out by a qualified electrician, who must perform the connection according to the regulations in force at the place of installation.

The electrical connection to the system is one of the most important operations to be carried out before domestic use.

The safety and efficiency of the generator and the user system itself depend on the correct connection. The generator must be connected directly to the utilities, and not in parallel to other power sources.

#### Correct connection

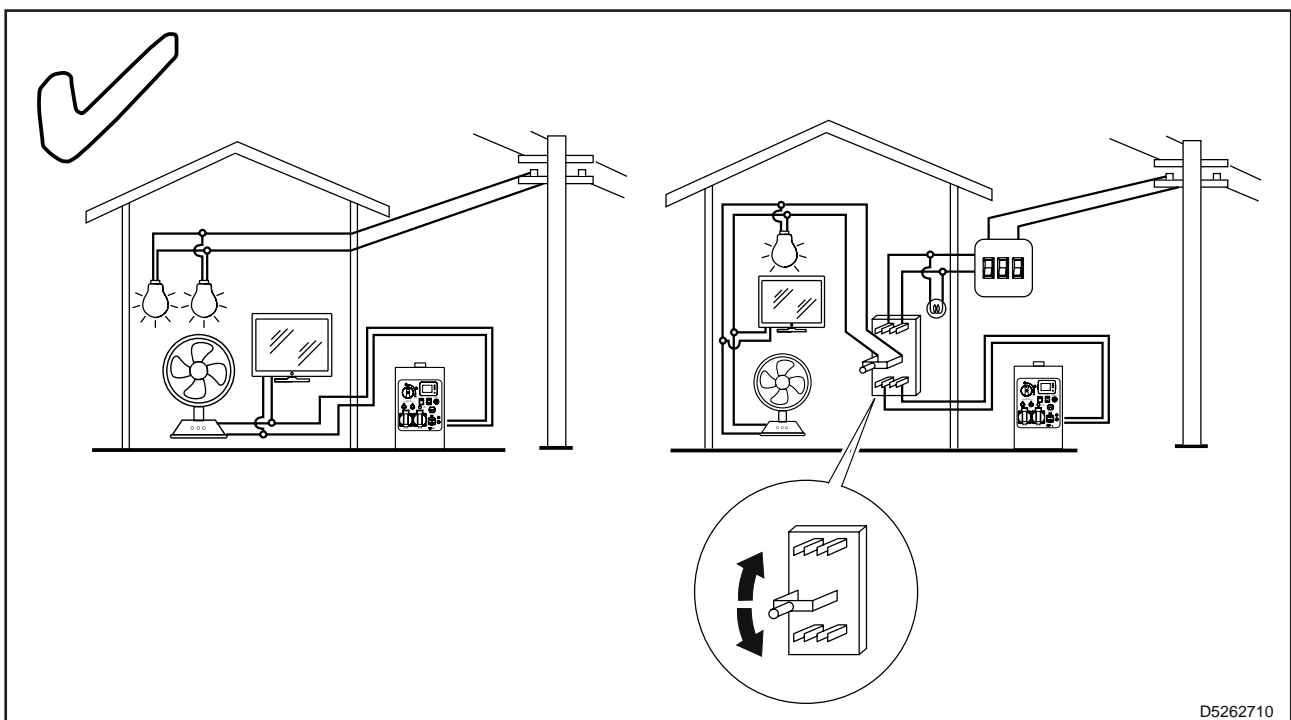

D5262710

## Improper connection

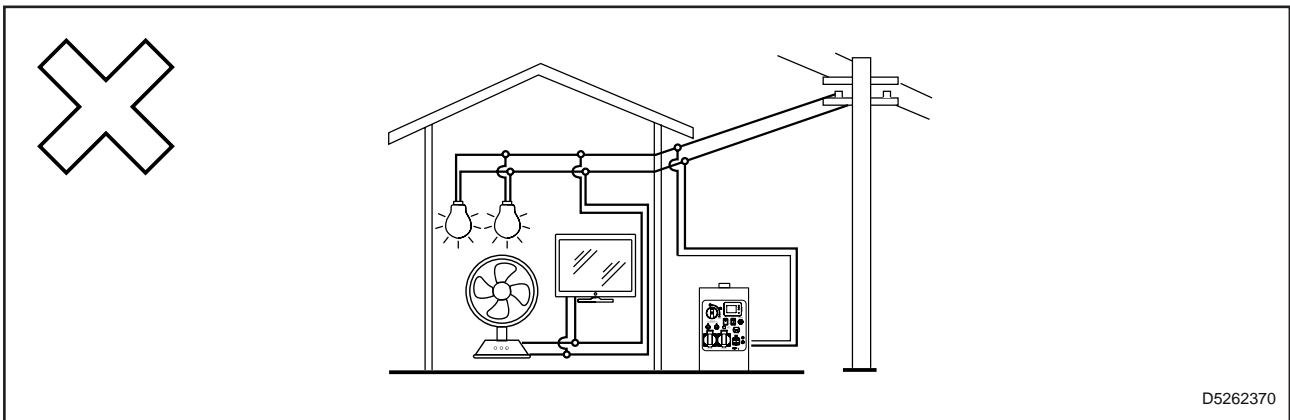

D5262370

### 6.2 Total load

Make sure that the total load is within the power of the generator.

### Alternating current load (AC)

<b>Purely resistive loads</b> (e.g. incandescent lamps, electric resistance stoves, electric water heaters, irons)	Power factor: 1	Rated power: $\leq 3600$ W
<b>Loads with high starting current</b> (e.g. power tools equipped with universal motor, angle grinders, portable alternative saws, portable circular saws, heat guns)	Power factor: 0.8 - 0.95	Rated power: $\leq 2880$ W
<b>Loads with high starting current</b> (e.g. asynchronous motors, compressors, hoists, concrete mixers, fluorescent lamps)	Power factor: 0.4 - 0.75	Rated power: $\leq 1440$ W

### Direct current load (DC)

Rated voltage: 12V	Rated current 8,3 A	Rated power: $\leq 96$ W
--------------------	---------------------	--------------------------

### 6.3 Simultaneous use of alternating current and direct current supply

To use the alternating current and direct current power supply simultaneously, the total power must not be exceeded. If the total power is exceeded, the OVERLOAD indicator light turns on.



## 6. Operation

### Example

Rated output of the generator		≤ 3600 W
Frequency	Power factor	Rated power
Alternating current (AC)	1.0	≤ 2880 W
	0.8	≤ 1440 W
Direct current (DC)		≤ 96 W (12V/8.3A)

## 6.4 Grounding



### WARNING

- **The machine is not equipped with a residual current circuit breaker, and must not be connected to a grounding system.**
- Protection against electric shock from indirect contacts is ensured by the “electrical separation” protection, with equipotential connection between all the masses of the machine.
  - The limitation of the electrical circuit extension is essential for safety purposes; do not power systems with a length greater than 200 meters.
  - The power cables of the equipment must be equipped with the protective conductor (yellow-green cable) to ensure the equipotential connection between the mass of the equipment and the mass of the machine; this provision is not valid for double insulated or reinforced insulated equipment recognizable by the symbol .
  - The cables must be suitable for the environment in which they are operated.  
In case of temperatures below 5°C, PVC cables become rigid and the PVC insulation tends to be cut at the first fold.
  - Electrical separation protection is not suitable if the machine is intended to power complex systems, or located in particular environments with a higher risk of electric shock.  
In these cases, it is necessary to adopt the electrical safety measures required by current regulations.  
Example:  
It is possible to install a high sensitivity, 30mA, residual current circuit breaker and ground the machine Neutral. This operation must be performed by a qualified electrician or at an authorised service centre.  
In this case, machine grounding is mandatory to ensure protection against indirect contacts by the residual current circuit breaker.  
Connect the machine to a grounding system via a cable using the grounding terminal (1).

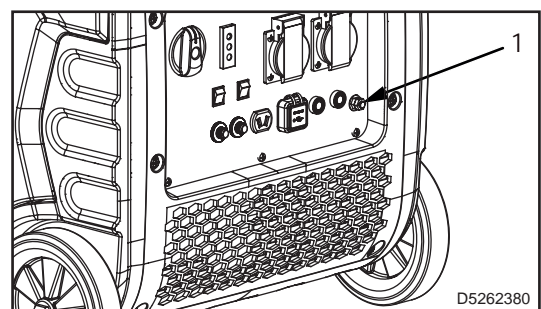

D5262380

## 6.5 Checks before start-up



### WARNING

- The machine is shipped without engine oil. Before starting the machine, fill it with oil. For the details, see “7. Maintenance”.

1. Check the oil and fuel levels. For details, see “7.2 Fuel” and “7.3 Engine oil”.
2. Check that there are no oil and fuel leaks.
3. Check that there is no flammable or dirty material around the machine.
4. Check that there are no unauthorized persons in the area adjacent to the machine.
5. Check that the connection cables between the generator and the user system comply with the rated voltages of the system.  
The type of cable, section and length must be sized according to the environmental conditions of installation and local regulations.
6. Connect the utilities to be powered using suitable cables and plugs, in excellent condition.

## 6.6 Starting and stopping the engine

### 6.6.1 Starting the engine

1. Turn the engine speed adjustment switch (ESC) to the OFF position.

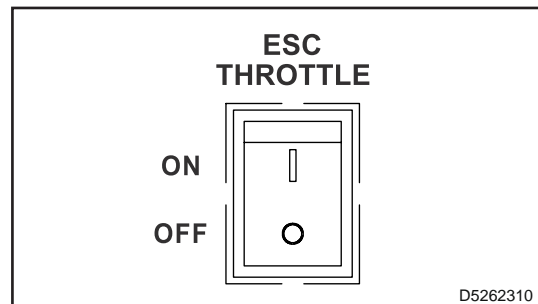

2. Turn the multi-function switch to the CHOKE position.



### WARNING

- When the engine is hot or the air temperature is high, turn the knob to the ON position.

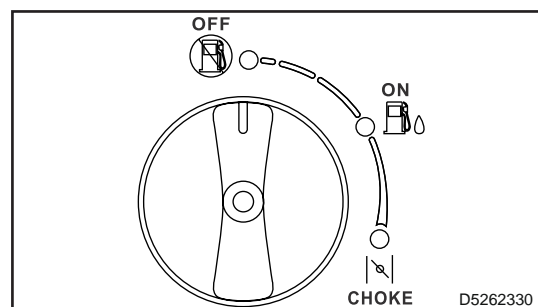

3. Pull start.  
Pull the start handle until you feel resistance, then pull vigorously in the arrow's direction.  
Gently return the starter handle to its position, without hitting the engine.

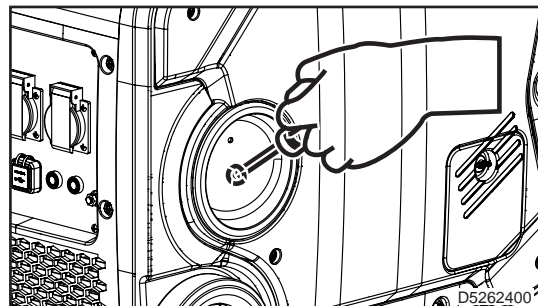

## 6. Operation

4. Electric start.  
Press the electric start button and wait for the engine to start.

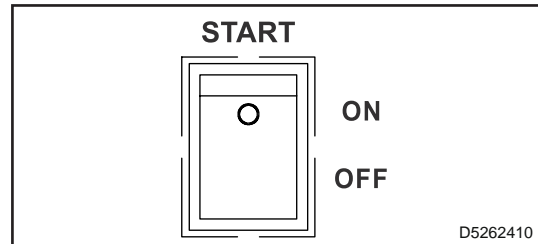

5. After starting the engine, turn the multifunction switch to the ON position.

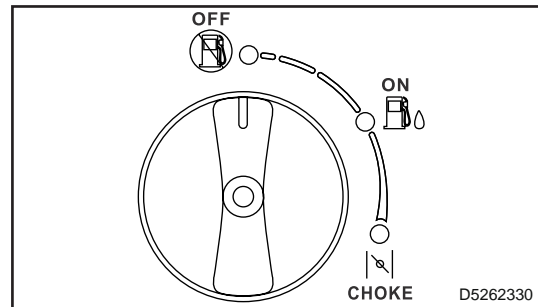

6. Turn the engine speed adjustment switch (ESC) to the ON position.

### Important

- Allow the engine to warm up for a few minutes before drawing power from the generator.

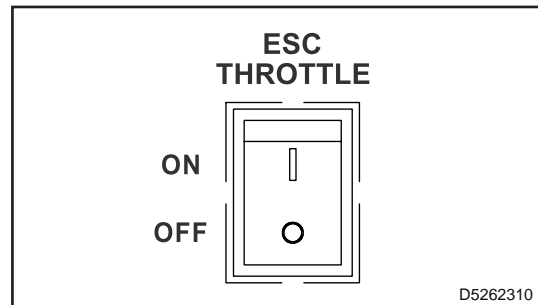

## Stopping the engine



### WARNING

- In case of emergency, turn the multi-function switch to the OFF position.

1. Disconnect or turn off any load connected to the generator,



### Important

- Allow the engine to cool down by letting it run for about 60 seconds with no loads attached before stopping it.

2. Turn the multi-function switch to the OFF position.

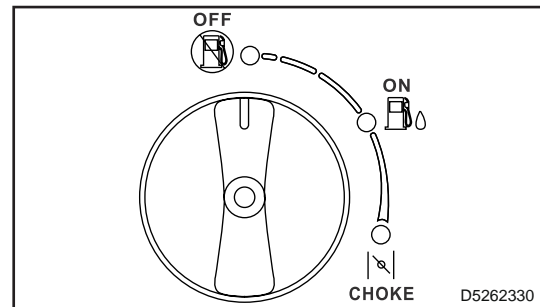
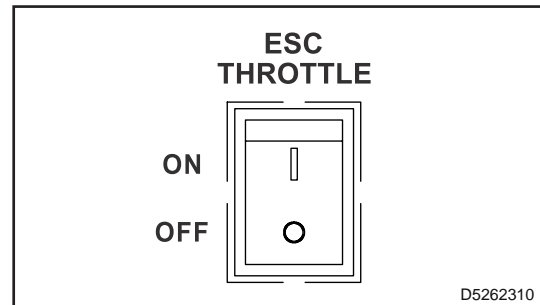

## 6. Operation

### 6.7 Alternating current operation (AC)



#### WARNING

- Check that all the electrical equipment, including the lines and the sockets, are in good condition before connecting them to the generator, and that the load current of the socket is suitable for the nominal current of the socket.
- Check that the total load falls within the generator's nominal output. For the details, see "6.2 Total load".
- Check that all electrical devices are switched off before connecting them.

1. Start the engine. For the details, see "6.6.1 Starting the engine".



#### Important

- If the generator is connected to several loads or electrical utilities, connect the one with the highest starting current first, and then the one with the lowest starting current.

2. Check that the AC generation pilot indicator light (1) is switched on.
3. Connect the plug to the sockets (2).
4. Turn on the electrical devices.

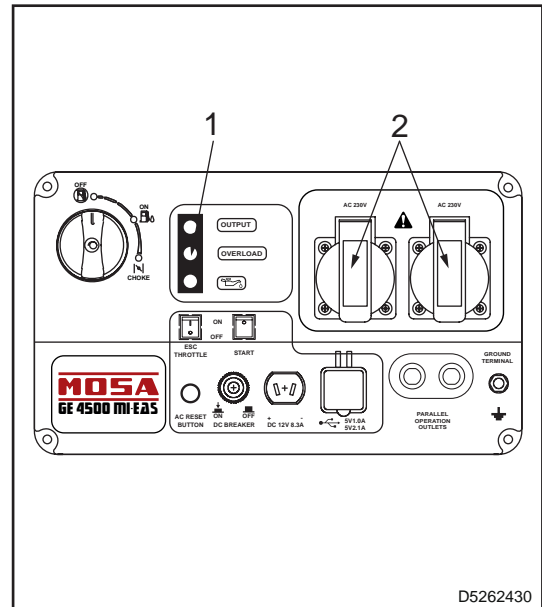

D5262430

## 6.8 Direct current operation (DC)

### 6.8.1 Charging a battery



#### WARNING

- Lead batteries generate hydrogen gas and are dangerous because they could cause explosions. While charging the battery, wear protective gloves and goggles, do not smoke and do not move material that could generate sparks close to the unit.
- Do not disconnect the cables while charging.
- Battery electrolyte is diluted sulphuric acid and can damage both the clothes and the skin. If it comes in contact with clothing or skin, rinse immediately with plenty of water. If it is sprayed into the eyes, wash immediately with fresh water and consult a doctor.



#### Important

- Only use the supplied cable.

1. Start the engine. For the details, see “6.6.1 Starting the engine”.
2. Check that the DC current protection is turned ON.

#### Note

- When the nominal value is exceeded, the protection is automatically released to pos. OFF. To start recharging, press the protection ON again. If the protection clicks again, contact the service centre for repair.
3. Turn the engine speed adjustment switch (ESC) to the OFF position.
  4. Check that the lead-acid battery to be charged has a rated voltage of 12 Vdc.
  5. Connect the battery charger red cable to the battery positive terminal (+).  
Connect the black battery charger cable to the battery negative terminal (-).

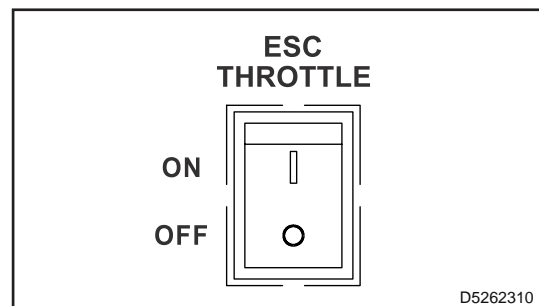
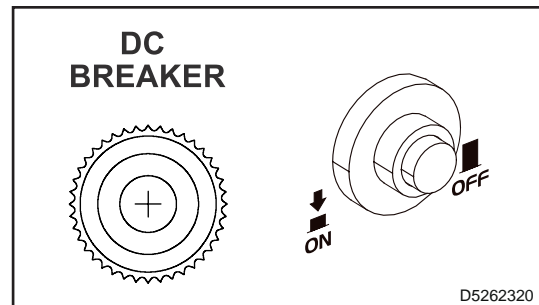

#### WARNING

- Do not reverse the positions.
- Securely connect the cables to the battery terminals to prevent them from getting detached while charging.

6. Refer to the battery instruction manual to determine when the charge is complete.

## 6. Operation

### 6.9 Connecting in parallel mode



#### WARNING

- The parallel box is sold on request.
- Only use the parallel box provided by MOSA.
- Connect the parallel box only to the MOSA inverter generators.  
The generators must be of the same model. Example: GE 4500 MI-EAS with another GE 4500 MI-EAS
- Do not disconnect the parallel cables while the generator is running and the power cables are connected.

1. Connect the two generators to the parallel box (1) using the parallel outputs (2).
  - Red to Red / Black to Black / Earth to Earth connection.



#### Important

- Make sure that the cables are connected correctly to the generators.  
If they are connected incorrectly, the generators will not deliver any power and you will need to turn them off and on again after connecting them correctly.

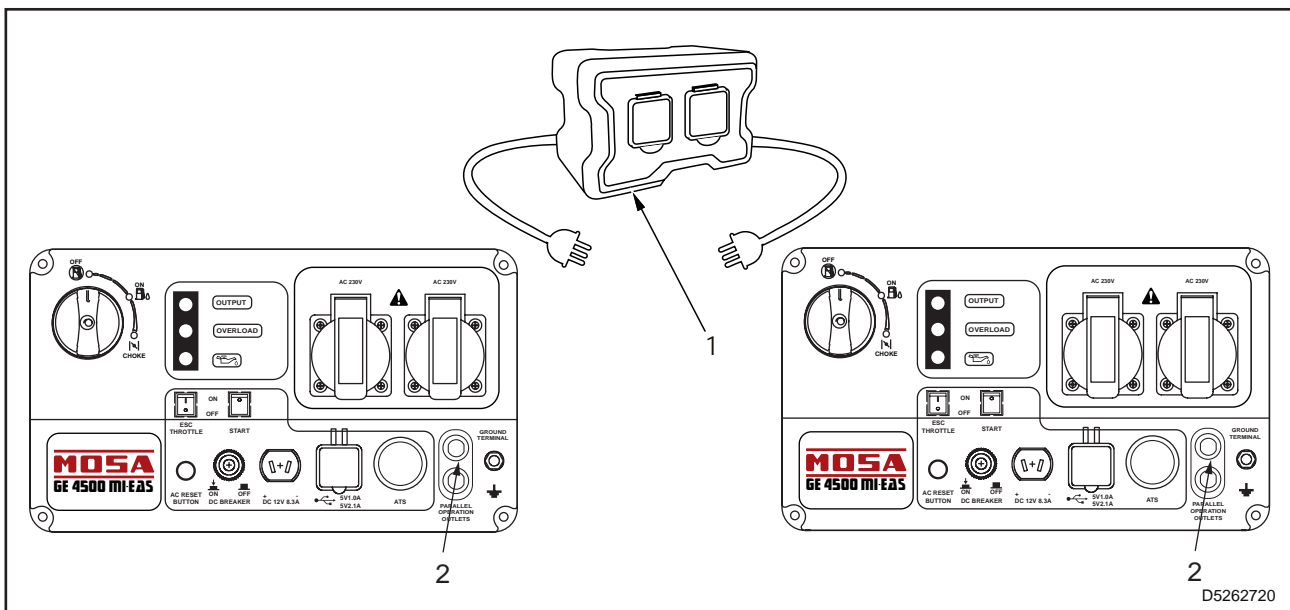

2. Start the first generator and wait for the pilot green warning lamp to light up. Start the second generator and wait for the pilot green warning lamp to light up on the second generator as well. For the details, see “6.6.1 Starting the engine”.

3. Take the load from the generators connected in parallel using the sockets on the parallel box.

**Note**

- The power delivered is split halfway between the two generators.
- The maximum withdrawable power from the generators connected in parallel is the sum of the rated powers of each single generator. If the required power exceeds the total sum, the overload protections of the individual generators will be triggered by removing voltage.
- During parallel operation, the AC voltage is also present on the sockets of the generators and it is therefore possible to power other equipment.  
The display will indicate the current and the total power delivered by the generator, that is, both the one delivered through the parallel box and the one delivered by the on board sockets.
- If the AC overload protection is tripped on one of the two generators, all the load connected to the parallel box is transferred to the other generator; this could cause the AC overload protection to be tripped even on the second generator, if the power currently drawn from the parallel box is greater than the nominal power of the generator

## 6.10 Troubleshooting

### The engine doesn't start

Issue	Cause	Remedy
The fuel does not reach the combustion chamber	Fuel tank empty	Fill the fuel tank
	The fuel tank cap vent is set to "OFF".	Set to "ON"
	Fuel filter clogged	Clean the fuel filter
	Carburettor clogged	Clean the carburettor
Spia del livello olio motore accesa	Oil level is low	Add engine oil
L'avvio del motore con la maniglia o a strappo non funziona perchè la scintilla della candela è scarsa	Dirty or wet spark plug	Clean or dry the spark plug
	Faulty ignition system	Contact the service centre

### Il generatore non produce corrente

Cause	Remedy
The direct current (DC) protection is set to "OFF"	Set to "ON"
The AC generation pilot indicator light switches off	Stop the engine and start it again

## 7. Maintenance



### WARNING

- Before proceeding with maintenance, carefully read section “2. Safety”.
- Place the generator on a level surface and remove the spark plug cap. for details see “7.6 Checking and replacing the spark plug”.

### 7.1 Ordinary Maintenance Schedule

Items		Frequency	Each time	First 1 month or first 20hrs of operation	Every 3 months or every 50hrs of operation	Every year or every 100 hrs of operation
Engine oil	Check-Refill		√			
	Replace			√	√	
Reduction gear oil (if equipped)	Oil level check		√			
	Replace			√	√	
Air filter element	Check		√			
	Clean			√		
	Replace				√	
Deposit Cup (if equipped)	Clean					√
Spark Plug	Check-adjust					√
	Replace			Every year or 250 hrs of operation		
Spark arrester	Clean				√	
Idling (if equipped)*	Check-adjust					√
Valve clearance *	Check-adjust					√
Fuel tank & fuel filter *	Clean					√
Fuel line	Check			Every 2 years (change if necessary)		
Cylinder head, piston	Clean up carbon *			<225cc, every 125hrs ≥225cc, every 250hrs		
* These items should be maintained and repaired by our authorized dealer, unless the owner has appropriate tools and is proficient with mechanical maintenance.						

## 7.2 Fuel

Only use gasoline and fill the tank with clean fuel.

1. Stop the engine and wait for it to cool down.
2. Rotate the tank cap (1) counter clockwise and remove it.

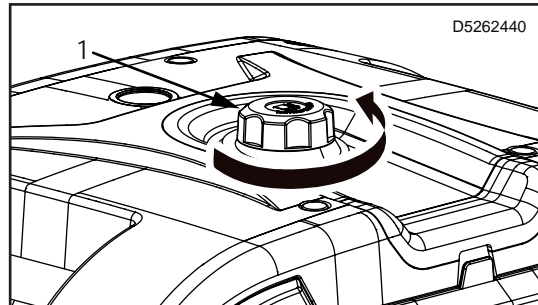

3. Fill the fuel tank up to the red line (2) of the maximum level (Max.), and immediately dry any spilled fuel.
  - Tank capacity: 5 litres
4. After refuelling, tighten the cap (1) securely.

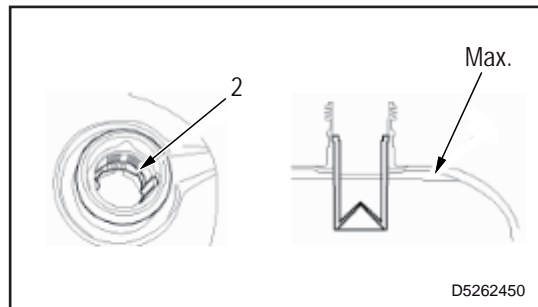

## 7.3 Engine oil

- To ensure adequate protection of the engine and keep it efficient for a long time, use only oil for 4-stroke automotive engines. Using different oils can reduce the life of the engine.
- The viscosity must be appropriate to the ambient temperature.

### Refuelling and checks



#### WARNING

- The machine is shipped without engine oil. Before starting the machine, fill it with oil.
- Before refuelling, read “2.9 Precautions during fuel and engine oil filling” carefully.
- Do not introduce more oil than indicated in the engine manual. Combustion of excess oil may result in increased engine revolutions.

1. Place the generator on a level surface.
2. Remove the access cover (1) to the engine tank.



## 7. Maintenance

3. Remove the engine fill cap (2) and wipe the oil level dipstick (3) with a cloth.
4. Insert the cap (2) into the filler neck without screwing it in, and remove it again to check the oil level on the dipstick (3).
  
5. If the oil level is near or below the lower limit mark (Min.), fill the oil to the upper limit mark (Max.) (lower edge of the filler hole).
  - Oil: SAE SJ 15W-40 - API service SE or higher
  - Tank capacity: 0,35 litres
6. Install the cover (1).

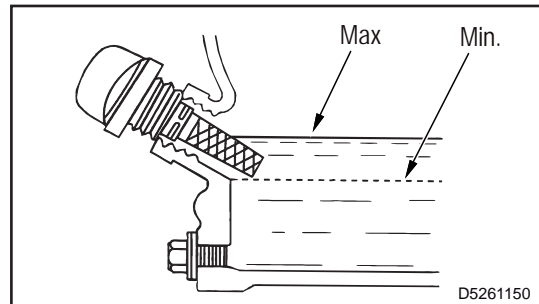
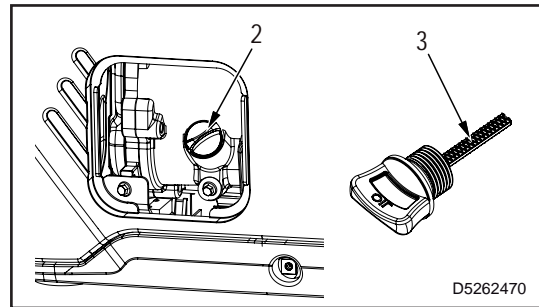

### Replacement

1. Place the generator on a level surface and start the engine for a few minutes to heat the oil. For the details, see "6.6.1 Starting the engine".
2. Remove the access cover (1) to the engine tank.
  
3. Remove the oil drain pipe (2) from the machine.
4. Place a container under the cap (3) to collect the drained oil.
5. Unscrew the cap (3) and tilt the generator to let all the
6. Fill with new oil. For the details, see "Refuelling and checks".

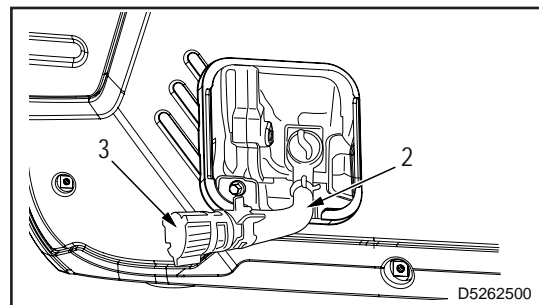
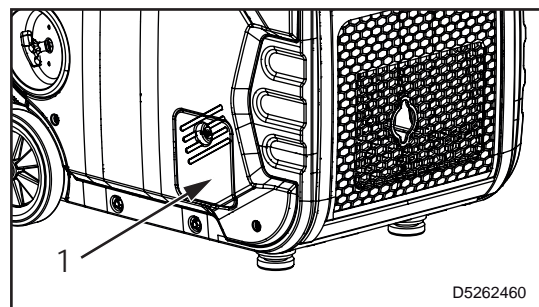

## 7.4 Engine air filter



### WARNING

- If the generator runs in rooms with a lot of dust, clean the air filter every 10 hours and replace it every 25 hours.

### 7.4.1 Cleaning

1. Remove the screws (1) and the cover (2).

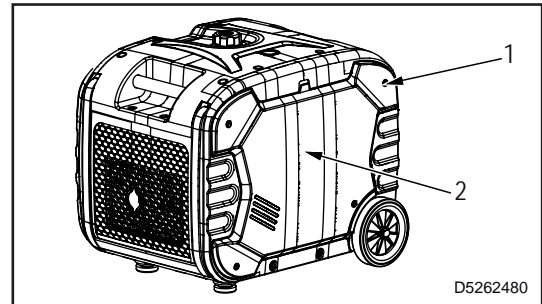

2. Remove the screw (3) and the cover (4).
3. Remove the air filter element (5).
4. Wash the element with a solvent and dry it.
5. Wet the element with oil and squeeze it out gently to remove any excess oil.

#### Note

- The element should be wet, but it shouldn't drip.

6. Insert the element into the filter case ensuring that the surface adheres to the case.
7. Install the cover (4) and tighten the screw (3).
8. Install the cover (2) and tighten the screws (1).

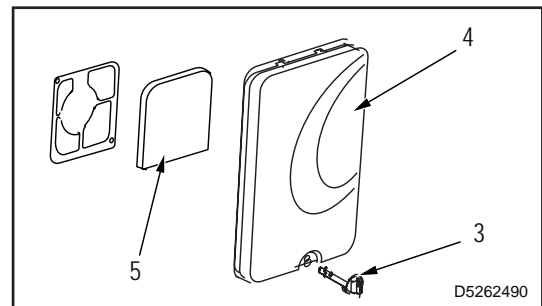

### 7.4.2 Replacement

Replace the filter every 50 operating hours or every 3 months, whichever comes sooner.

## 7. Maintenance

### 7.5 Cleaning the spark guard



#### WARNING

- Wait for the engine to cool down before performing this maintenance operation.

1. Lift the handle (1), remove the screws (2) and the cover (3).

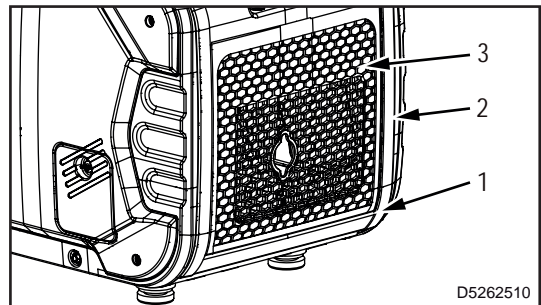

2. Loosen the bolt (3) and remove the cap (4) and the grid (5).

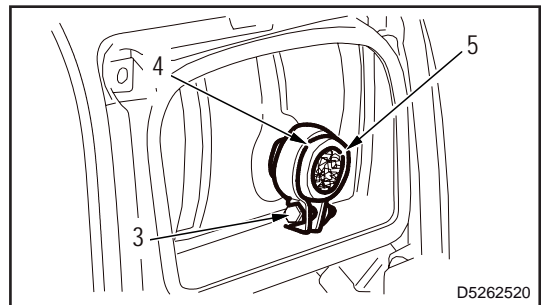

3. Using a screwdriver, remove the spark arrester (6).

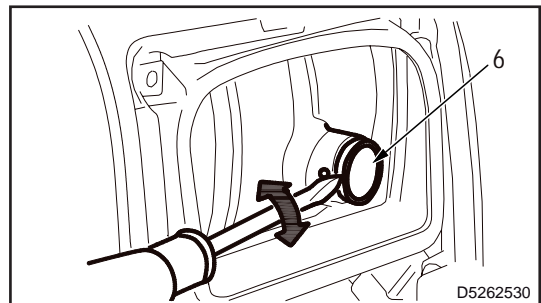

4. Using a metal brush, gently brush the grid (5) and the spark arrester (6).  
If they are damaged, replace them.
5. Install in the removal order.

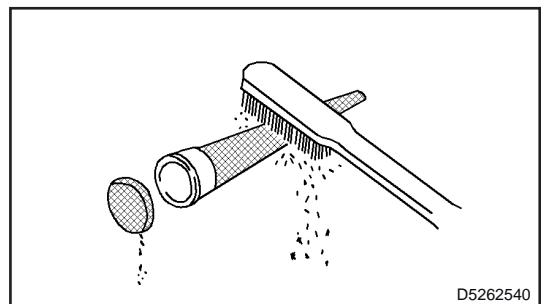

### 7.6 Checking and replacing the spark plug

1. Remove the screw (1), remove the cover (2), and remove the spark plug cap.
2. Use the wrench supplied and unscrew the spark plug.
3. Use a brass brush to remove soot and dirt and run a damp cloth to remove any residue.
4. Check the colour of the porcelain insulator; if it is light brown, it is not necessary to replace it.
5. Check that the distance between the electrodes (X) is correct.
  - Distance between the electrodes (X): 0.7- 0.8 mm
6. If you need to replace the spark plug, replace it with one of the same type.
  - Spark plug type: F7RTC
  - Spark plug tightening torque: 22 Nm
7. Install the cap and the cover (2).

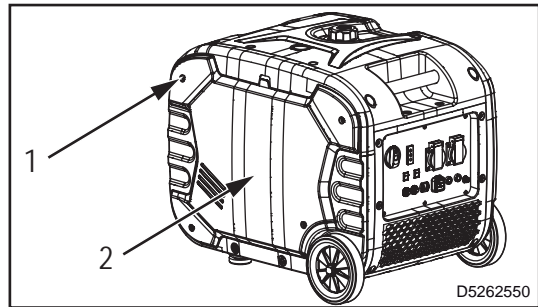

D5262550

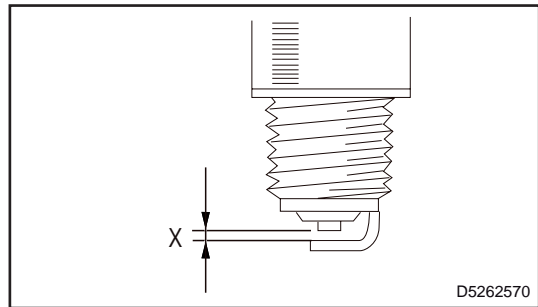

D5262570

### 7.7 Cleaning the fuel tank filter

1. Rotate the tank cap (1) counter-clockwise and remove it.
2. Remove the filter (2), rinse it with gasoline and remove the residue with a cloth.
3. Insert the filter and tighten the cap (1) securely.

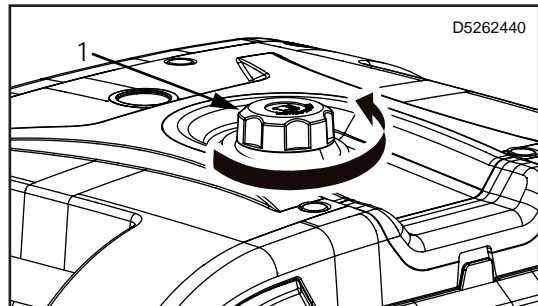

D5262440

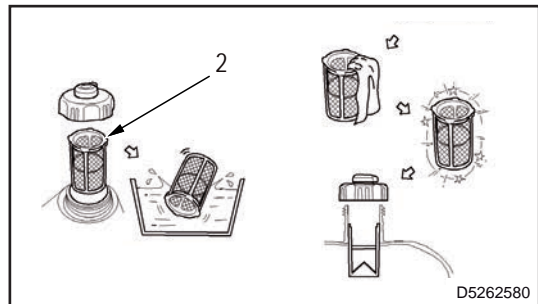

D5262580

## 7. Maintenance

### 7.8 Storage

- Carefully clean the fairings and all other machine parts.
- If the machine is not used for more than 30 days, make sure that the machine is protected from heat sources and from weather phenomena that can cause rust, corrosion of the components and damage to the machine.
- Completely empty the tank and the carburettor from the gasoline present, as it could irreparably damage the components of the engine power supply circuit if it deteriorates.  
Also, this reduces the fire risk of gasoline vapours.
- Protect the machine with a case and store it in a dry place.
- Use qualified personnel to carry out the operations necessary for storage.
- For correct engine storage, follow the instructions below.
  - Remove the spark plug, pour about 15 ml of engine oil into its seat and insert it again.
  - With the multi-function switch off, pull the start handle until you feel the compression.

### 7.9 Disposal



#### **WARNING**

- Before refuelling, read “2.11 Precautions for disposal of waste material” and “2.12 Disposal of the machine”.

In the event of disposal of the machine or parts of it (oils, hoses, plastic materials, etc.), comply with the regulations in force in the country in which this operation is carried out.







**MOSA**

**MOSA div. della BCS S.p.A.**  
Viale Europa, 59 20047 Cusago (Milano) Italy  
Tel.+39 - 0290352.1 [www.mosa.it](http://www.mosa.it)